

# **TA-530wa Wireless A/V Transport**

## **Users' Guide**

Copyright© 2005 Taifatech Inc. All rights reserved.  
Rev. 1.14

[www.taifatech.com](http://www.taifatech.com)

2005/7/12  
1.06e

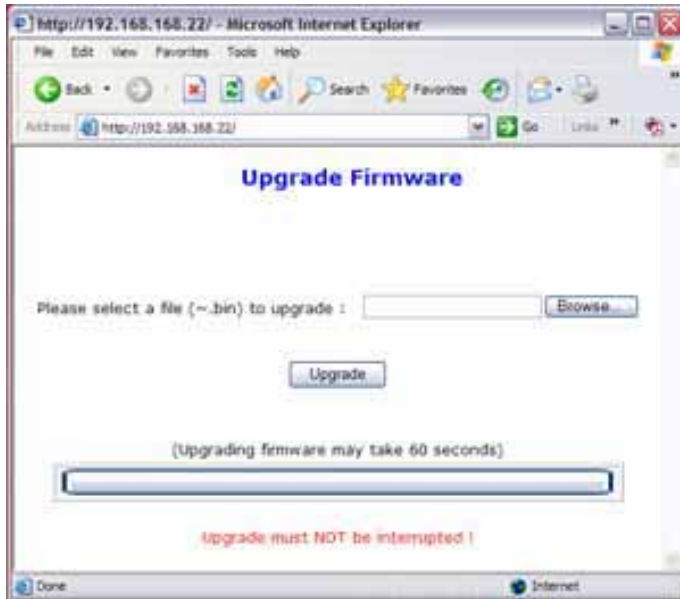

## Factory Default

To reset the configuration to factory default setting, hold Source and Up and turn on the power. The system will automatically load the factory default setting and turn on. This will lose all users' configurations.

## Contents

Introduction.....	5
Applications.....	5
Hardware Description.....	6
The Transmitter.....	6
IR Blaster.....	8
The Receiver.....	8
Console.....	10
The Transmitter.....	10
Configuring the Transmitter.....	11
Download Mode.....	11
Setup Mode.....	11
Operation Mode.....	13
Input Source.....	14
Wireless Channel.....	14
MPEG Compression Rate.....	16
Analog tuner channel.....	18
Input Volume.....	18
Scan analog tuner.....	19
The Receiver.....	19
Configuring the Receiver.....	19
Download Mode.....	19
Setup Mode.....	20
Search all transmitter.....	21
Factory Reset.....	22
Operation Mode.....	22
Video Source.....	23
Wireless Channel.....	24
MPEG compression rate.....	26
TV system.....	27
Remote Controller.....	30
Descriptions of the keys.....	31
Menu Key.....	32
IR Blaster (IR out).....	32
Use Computer as a Receiver.....	32
Making the connection.....	33

Configure network parameters of computer .....	33
Setting up software decoder on your computer	33
VLC media player.....	34
WLAN connection.....	34
LAN connection.....	34
Accessing to the HTTP server of TA-530wa.....	35
Firmware upgrade .....	37
Factory Default .....	38



## Firmware upgrade

The Transmitter and Receiver support HTTP download function to upgrade firmware. On the other words, users can use web page in the Transmitter or Receiver to upgrade firmware. Users need to put the new firmware in computer and connect the computer and the Transmitter or Receiver with Ethernet cable. To upgrade firmware, hold Enter and Source button and turn on the power. After that, type the IP address, 192.168.168.21 for the Transmitter or 192.168.168.22 for the Receiver, in the address area of the browser. Browse the route to the place where you save the new firmware and click Upgrade to upgrade.



Click channel Up or Down button to select TV channel and use the drop down menu to select the input source. After selecting the input source, press submit to transmit the audio and video data to computer.

## Introduction

The TA-530wa Wireless A/V Transmitter and Receiver are integrated with Taifatech's TF-530 Wireless Media Streaming Controller that combines Wireless, Ethernet, video host interface and Web Server in a single chip. The performance of the TF-530 is greatly enhanced by the many on-chip accelerators and DMA engine.

The TA-530wa Transmitter and Receiver are used to connect different A/V sources such as cable TV, Personal Video Recorder (PVR) and DVD player to the TV using industry standard 802.3 Ethernet or 802.11 wireless technology. By using wireless connection or wired (CAT5 cable) connection from the Transmitter to the Receiver, the Transmitter compresses the audio and video data in MPEG2 Transport Stream format and the Receiver decodes the data and sends audio and video to the TV.

In addition to using a Receiver to watch programs on a TV, computers capable of decoding MPEG 2 Transport Streams can be used to view the same program. Notebook computers equipped with wireless cards can be used as portable LCD televisions.

## Applications

There are two scenarios for using the wireless AV.

Scenario I: Transmitter and Receiver via wireless or Ethernet

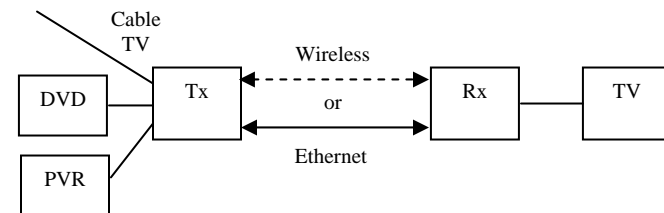

## Scenario II: Transmitter and computer via wireless or Ethernet

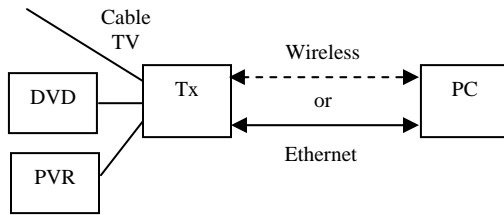

## Hardware Description

### The Transmitter

The TA-530wa transmitter board provides interfaces for one Wireless mini-PCI card, one 10/100Mbps Ethernet, two RS-232, analog cable TV tuner, S-video, one set of composite jacks, mini A/V jack, IR blaster and power connector. The descriptions for the interfaces are as follow:

Interface	Description
Mini PCI	For 802.11a/b/g Wireless mini PCI card
10/100M Ethernet	RJ-45 female Ethernet port for LAN connection
RS-232 (2)	Monitoring and debugging RISC CPU of TF-530
TV Tuner	Connection with analog cable TV
S-video	Connection with video source device
Composite Jacks	Connection with audio and video source devices
Mini A/V jack	Connection with audio and video source devices
IR Blaster	Emits IR from remote controller 38kHz IR pass-through
Power	7.5V DC 1.5A power

Two diagnostic LED lights are located within each RJ-45 connectors. There are one LED lights, Power, located on the board. The descriptions of LED status are as follow:

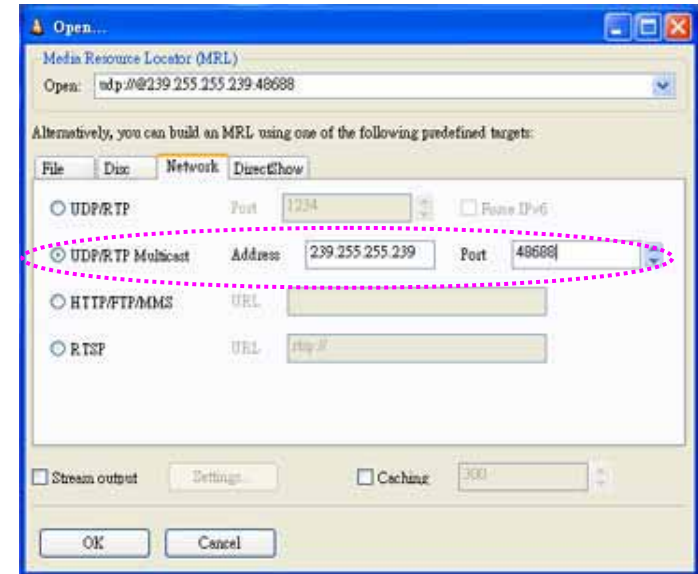

After configuration the VLC player, access the HTTP server of TA-530wa and enter to the web page. The audio and video data will be transmitted to the computer and displayed on it.

#### Notice:

1. Window XP (SP2) and 2k (SP4) have firewall function to block the packets. The firewall will also drop the video packets. To view the video, firewall function has to be disabled. It can be done by Start, Control panel, Windows Firewall and off. If users installed personal firewall will also block the video packets. Make sure your firewall does not block the packets.

### Accessing to the HTTP server of TA-530wa

A web interface is used to change the TV channel or input source from the computer. To access the Transmitter, type 192.168.1.21 in the address area of the browser. The browser should display a login page. Use the user name "user" and password "0000" to log in. As soon as you login, the transmitter transmits the video packets to your computer.

## VLC media player

The software can be downloaded from [www.videolan.org/vlc/](http://www.videolan.org/vlc/). There are many versions for different operating systems. Select the right version to download. Start the decoding software through the following sequences start, programs, videoLAN and VLC.



## WLAN connection

Select UDP/RTP and set the Port number to 48688 and press OK.

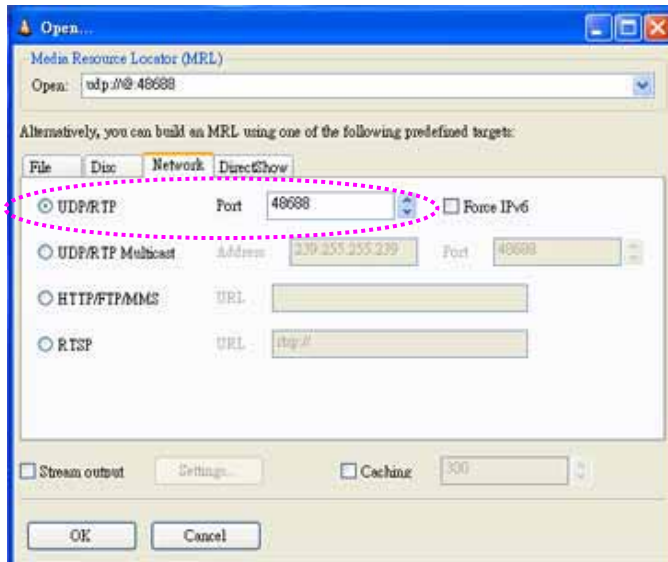

## LAN connection

The Transmitter will multicast the audio and video data in LAN. Difference transmitter ID has difference multicast address. The multicast addresses are 239.255.255.241 for Transmitter ID 1 and 239.255.255.242 for Transmitter ID 2 and so on. Select UDP/RTP Multicast and type the appropriate multicast IP address in Address space and set the Port number to 48688 and press OK.

LED	Status	Description
RJ-45 (Green)	On	Ethernet link is established.
	Blink	Active traffic on port
RJ-45 (Orange)	On	Ethernet link is established at 100Mbps.
	Off	Ethernet link is established at 10Mbps.
Power	On	Power on

Five push buttons located on the board are for the purpose of configuration and hardware reset, and one slide switch for power. The detail usage of the buttons will be shown in “Configuring the Transmitter” chapter.

The 7-segment 2-digit LED displays the status, source, configured parameters, MPEG-2 compression rate, LAN and WLAN channel and TV channel.

The following figure shows the locations of different components on the TA-530WA Wireless A/V Transmitter.

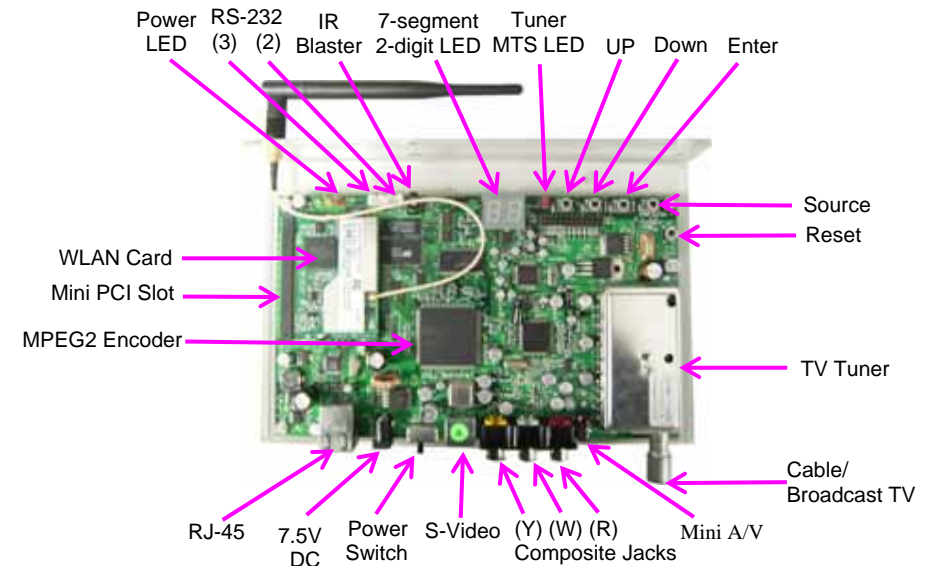

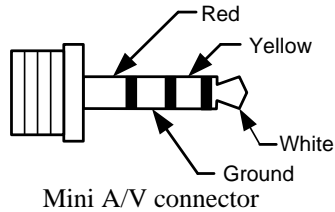
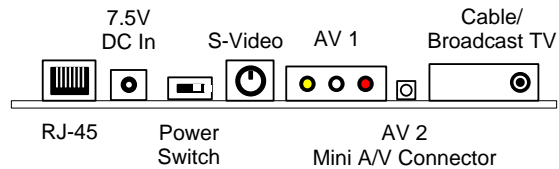

### IR Blaster

The IR Blaster connector is to connect the IR emitter cable (not supplied). The connection of the IR blaster cable is as follow:

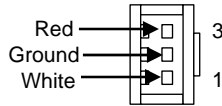

### The Receiver

The TA-530wa receiver board provides interfaces for one Wireless mini-PCI card, one 10/100Mbps Ethernet, two RS-232, one S-video, one set of composite jacks, IR blaster and power connector. The descriptions for the interfaces are as follow:

Interface	Description
Mini PCI	For 802.11 Wireless mini PCI card
10/100M Ethernet	RJ-45 female Ethernet port for LAN connection
RS-232 (1)	Monitoring and debugging RISC CPU of TF-530.
S-video	Connection with S-Video port of TV.
Composite Jacks	Connection with audio and video ports of TV.
IR Receiver	IR remote control for dedicated remote control and universal remote control's IR pass-through
Power	7.5V DC 1.5A power

The VLC media player will be used as an example.

### Making the connection

In order to connect to the Transmitter from a computer, an Ethernet Network Interface Card (NIC) or Wireless LAN Card is needed on the computer. For Ethernet connection, connect one end of Ethernet cable to the Ethernet port of the Transmitter and the other end to the computer. Alternatively, connect both the Transmitter and computer to an Ethernet Switch.

### Configure network parameters of computer

Configure the PC through the following sequences Start, Control Panel, Network Connections, right-click on the Network Connection icon, Properties, double-click on Internet Protocol (TCP/IP) and select "Use the following IP address".

Type in 192.168.1.10 in the IP address field. In the Subnet mask field, type in 255.255.255.0. Click OK and click OK again to save the changes.

If you use WLAN connection, scan the wireless stations and connect the Transmitter. Sometime users cannot find the Transmitter in wireless network list. That is because the Transmitter and users' WLAN card are in difference wireless frequency range. For instance, the default wireless setting of the Transmitter is 802.11a 5.0GHz frequency range but users' WLAN card only supports 802.11b/g 2.4GHz frequency range. At that time, users have to modify the Transmitter wireless mode to 802.11b/g. (Refer to the Transmitter WLAN channel) After that, users can find the Transmitter in wireless network list and select the Transmitter to connect.

Test the setup by using the ping command in a DOS Window. Under DOS, type ping 192.168.1.21. If you see a reply, then you are ready to access the Transmitter. Make sure that the Transmitter is turned on before testing the connection.

### Setting up software decoder on your computer

The VLC media player will be used as an example.

## Menu Key

There are eight items in menu. Press → key to show the followings:

1. Connection status including Transmitter and Receiver information and connection mode.
2. Change WLAN channel
3. Change audio format
4. Change TV system
5. TV tuner fine tune
6. TV tuner scan
7. MPEG compression bit rate
8. Power off

To modify these items, press Up or Down to modify them.

## IR Blaster (IR out)

There is an IR blaster (IR out LED cable not supplied) connector on the Transmitter. Connection with the IR blaster cable, users can use the remote controller of the device connected to the Transmitter to control it. The Transmitter have IR receiver which can receive 38kHz IR signal and translates it to WiFi protocol and transmits to the Receiver. The Receiver will return it to the original 38kHz IR signal and send out to the connected devices such as DVD player, PVR, etc...

## Use Computer as a Receiver

The Transmitter compresses audio and video data in MPEG-2 Transport Stream format and delivers it via industry standard 802.3 (Ethernet) or 802.11a/b/g (WiFi) protocols. Computers with LAN or WLAN cards can receive the MPEG-2 Transport Stream. Programs can be viewed on the computer by using the proper MPEG-2 Transport Stream decoding software. A notebook computer with wireless capability can even be used as a portable TV.

The Transmitter will deliver MPEG-2 Transport Stream through LAN or WLAN but it can deliver only one at the same time. Multicast will be used in delivering through LAN but unicast through WLAN. The setting of media player will be difference according to the connection.

Two diagnostic LED lights are located within each RJ-45 connectors and one power LED located on the board. The descriptions of LED status are as follow:

LED	Status	Description
RJ-45 (Green)	On	Ethernet link is established.
	Blink	Active traffic on port
RJ-45 (Orange)	On	Ethernet link is established at 100Mbps.
	Off	Ethernet link is established at 10Mbps.
Power	On	Power on
	Off	Power off

Five push buttons located on the board are for the purpose of configuration and hardware reset, and one slide switch for power. The detail usage of bush buttons will be shown in “Configuring the Receiver” chapter.

The 7-segment 2-digit LED displays the status, source, configured parameters, MPEG-2 compression rate, WLAN channel and TV channel.

The following figure shows the locations of different components on the TA-530wa Wireless A/V Receiver.

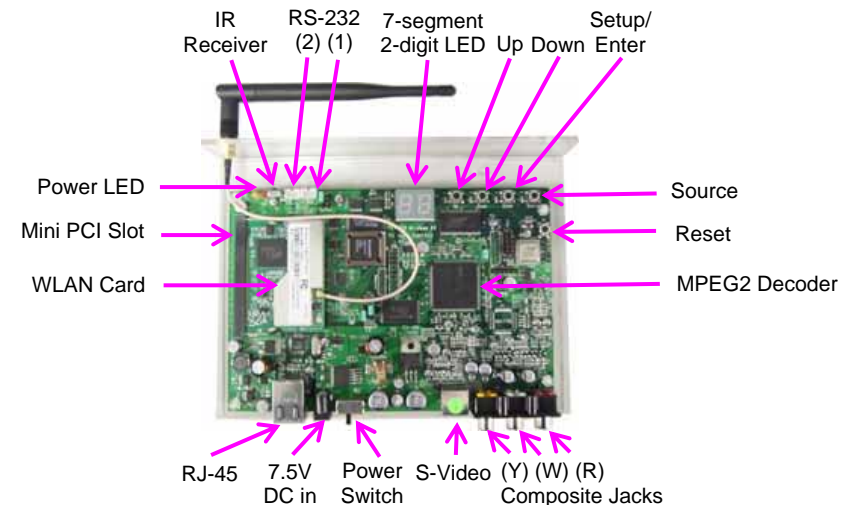

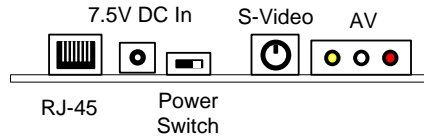

## Console

The RS-232 console ports located on the transmitter and receivers are for the purposes of monitoring and debugging. There are two CPUs embedded in the TF-530. The primary console is for monitoring and debugging the HTTP server and protocol handling processor, and secondary console for the dedicated I/O processor. To debug the TF-530, connect the RS-232 cable to primary RS-232 port.

One end of the RS-232 cable is a 3-pin connector and another end a DB9 (female) connector. The cable connection between the two connectors is as shown below. Connect the DB9 connector to the com port of PC and 3-pin connector to the Primary RS-232 port of the board.

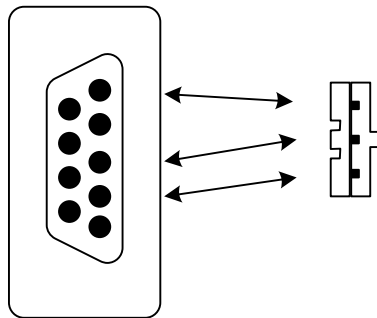

## The Transmitter

The main function of the transmitter is taking the audio and video data from Cable/broadcast TV, DVD and PVR then compressing them into MPEG 2 Transport Stream format and then delivering the data to the Receiver through LAN or WLAN.

The transmitter has two network interfaces, LAN and WLAN. The default IP addresses are 192.168.168.21 for both. In the current version, the Transmitter delivers the audio and video data only through one interface at a time.

## Descriptions of the keys

No.	Key	Description
1	Power	Power on or off
2	Mute	Mute the output sound
3	0 to 9	Number for analog tuner or digital tuner channel
4	100	Number for analog tuner or digital tuner channel which exceeds 99
5	Display	Display OSD for 10 second
6	Ch+	Tuner channel up
7	Ch -	Tuner channel down
8	Vol+	Input Volume up
9	Vol-	Input Volume down
10	Jump	Jump to previous tuner channel
11	Menu	Enter to setup menu
12	↑	Use with the combination of Menu key to change the parameters.
13	↓	Down: use with the combination of Menu key to change the parameters.
14	←	Left: use with the combination of Menu key to choose the parameters.
15	→	Right: use with the combination of Menu key to choose the parameters.
17	OK	Press it after configuration
16	MTS	Select output audio format
17	Source	Select input source, TV, S-Video, AV1, AV2
18	Tx 1	Change to transmitter 1
19	Tx 2	Change to transmitter 2
20	Tx 3	Change to transmitter 3
21	EPG	Electronic Program Guide
22	Tel Txt	Teletext
23	Red	Teletext hot key
24	Green	Teletext hot key
25	Yellow	Teletext hot key
26	Blue	Teletext hot key
23	Subtitle	Select the language displayed on TV
24	Sound	Select the audio language

## Remote Controller



## Configuring the Transmitter

Before discussing the configuration steps, users need to understand the operation sequence of the Transmitter. When powered on, the Transmitter will start in the download mode and then enter into the setup mode. After that, it will get into the operation mode.

The network parameters and system configurations have to be set in the setup mode. Configuration for multiple receiver support is also done in the setup mode.

### Download Mode

In this mode, the transmitter is initializing the system. When powered on, the LED will display “L-” first, followed by “SE”.

LED Display	Description
	Download Mode
	Setup Mode

After initialization, the TA-530wa will enter into the operation mode. To configure the network parameters, as soon as power on, users have to press Enter key until “td” appears on the LED.

### Setup Mode

Users can setup the transmitter ID, quantity of receiver allowed to connect, four-digit password and IP address in hexadecimal number in this mode. Users need to learn how to use the push buttons, Exit, Enter, Down and Up (refer to the diagram). The Enter button is used for selection and jumping to the next parameter, exit for exiting and up and down for configuring the parameters.

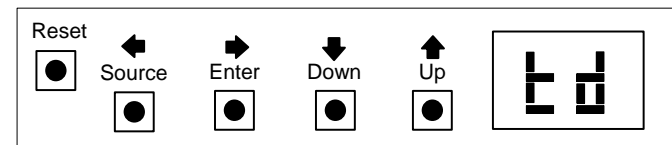

To enter the setup mode, press the Enter button until “td” appears on the LED display as soon as power on. A flashing “td” indicates that it is the transmitter ID. Press Enter again; the LED will display the current ID number. The Transmitter ID can be changed by using the Up or Down button. When completed, press Enter to jump to the next parameter.

The Transmitter supports 4-digit password to protect the video contents accessing from unauthorized Receiver or computer. Receivers have to key in the password to access the video content. A 4-digit password can be set up in P1-P2 sequence. P1 is the first two digits of the password and P2 is the second two digits of the password. The default password of the Transmitter is “0000”. A flashing “P1” indicates first two digits of the password. Press Enter to select and Up and Down to change the password. After that, press Enter again to jump to the second two digits of the password and the LED displays flashing “P2”. Same as the sequence above, press Enter to select and Up and Down to change and then Enter again to save the password and jump to IP address. If a password is entered, the Receiver must have the same password in order to connect the Transmitter.



The Transmitter has two network interfaces, LAN and WLAN, and both use the same IP address. A flashing “n1” indicates that it is the first eight-bits of the IP address. Press Enter again; the LED will display the first eight-bits of the IP address in hexadecimal number. Users can configure the left flashing digit by using the Up or Down button. When completed, press Enter to jump to the next digit. The IP address will be displayed as “n1.n2.n3.n4” sequence.

Multi-receiver can connect one transmitter to view the same video. In this application, only the master receiver has authority to change input source and modify the setting. Listener (listen receiver) can watch the same video only. The transmitter can accept whether one or multi receivers to connect it at a time. It will display as connection mode (co). If the connection mode is 00, multi receivers can connect the transmitter at a time. If it is 01, only one receiver can connect it. The menu structure is a loop structure so after configuring the IP addresses, press Exit to leave.

The Source ( ← ) button can be used at any time. When it is pressed, the system will jump out of the setup mode and enter into the operation mode.

In addition to the LED displays described in the Transmitter, the Receiver has two additional displays, logout and no connection.

The Receiver supports multiple Transmitters but can only connect to one Transmitter at a time. To connect to a different Transmitter, first log out of the current transmitter by using logout function and then the Receiver will scan for all Transmitters in the same channel, finally select the desired Transmitter. If the Receiver is not connected to a Transmitter, the LED displays “--”.

LED Display	Description
	Logout
	No connection with transmitter.

Mono	Mono sound
SAP	SAP sound

There are many TV systems according to the line and field rate, video bandwidth, audio carrier frequency and chroma subcarrier frequency and channel bandwidth. The receiver have good flexibility to connect multi TV systems. The TV system will be fixed when users use definite tuner scan mode to scan TV program but it can be changed when users use TUNER SCAN ALL to scan TV program. TV system is displayed as follow

OSD	Description
TV SYSETM M/N	TV system for NTSC (M)
TV SYSTEM B	TV system for PAL (B)
TV SYSTEM D/K	TV system for PAL (D,K)
TV SYSTEM I	TV system for PAL (I)
TV SYSTEM G/H	TV system for PAL (G,H)

TV fine tune is an advanced feature for users who want to manually adjust TV channel frequency.

OSD	Description
TV FINE TUNE	+++ means plus 62.5kHz. - - - means reduce 62.5kHz.

The same as TV system, difference tuner scan method should be used in difference country.

OSD	Description
TUNER SCAN NONE	
TUNER SCAN	Scan tuner
TUNER SCAN M/N	Scan tuner as NTSC (M) system
TUNER SCAN JP	Scan tuner as NTSC (M) system. Japan also uses NTSC (M) but they have different channel assignment.
TUNER SCAN ALL	Scan tuner as all systems.
TUNER SCAN G/H	Scan tuner as PAL (G,H)
TUNER SCAN B	Scan tuner as PAL (B)
TUNER SCAN D/K	Scan tuner as (D,K)

The different displays of 2-digit 7-segment LED in setup mode are as follow:

LED Display	Description
	<b>transmitter Id:</b> The transmitter ID number
	<b>Password 1:</b> The first two-digit number of password.
	<b>Password 2:</b> The second two-digit number of password.
	<b>WLAN IP number 1:</b> The first eight-bit of WLAN IP address. For example, n1 of 192.168.2.21 is 192. 192 is shown in hexadecimal C0.
	<b>WLAN IP number 2:</b> The second eight-bit of WLAN IP address. For example, n2 of 192.168.2.21 is 168. 168 is shown in hexadecimal.
	<b>WLAN IP number 3:</b> The third eight-bit of WLAN IP address. For example, n3 of 192.168.2.21 is 2 and it is shown in hexadecimal.
	<b>WLAN IP number 4:</b> The fourth eight-bit of WLAN IP address. For example, n 4 of 192.168.2.21 is 21 and is shown in hexadecimal.
	<b>Connection mode:</b> Configure whether one or multi receiver can connect the transmitter at a time.

### Operation Mode

The Transmitter will listen at LAN and the last wireless channel to get connection from Receivers. At that time, the Transmitter doesn't decide from which interface the audio and video data will be delivered. It depends on the Receiver. The Transmitter only delivers the audio and video data from one interface at a time.

The LED displays the current video source upon entering the operation mode. In this mode, the source button can be used to select the A/V inputs (TV, AV1, AV2, S-Video). The Enter button can be used to

choose the wireless channel and MPEG compression bit rate. The Up or Down button can be used to modify the TV channels wireless channel and MPEG compression rate.

The procedures will be discussed in this section. All settings configured in the Operation mode will be sent to the Receiver where the same changes will be applied automatically.

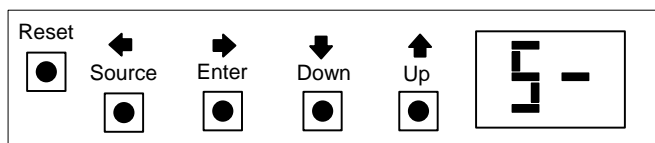

### Input Source

The Source button is used for changing the video source only. Press Enter until the LED displays the video source. By using the source button, users can select the video source. When the LED displays analog tuner channel, the analog tuner channel can be selected via the Up and Down button. The description of LED display is as follow:

LED Display	Description
	S-video input
	Analog tuner channel
	AV1 input
	AV2 (mini AV) input

### Wireless Channel

The LED will display the WLAN channel when the Enter button is pressed. Use the Up or Down button to change the channels. After that, press Enter button to save the new wireless channel. The Transmitter

	Compressed Bit Rate 7: The MPEG compressed bit rate is 7.2M/sec for WLAN and LAN.
	Compressed Bit Rate 8: The MPEG compressed bit rate is 8.0M/sec for WLAN and LAN.
	Compressed Bit Rate 9: The MPEG compressed bit rate is 9M/sec for WLAN and LAN
	Compressed Bit Rate 9: The MPEG compressed bit rate is 10.8M/sec for WLAN and LAN
	Compressed Bit Rate 9: The MPEG compressed bit rate is 12M/sec for WLAN and LAN
	Compressed Bit Rate 9: The MPEG compressed bit rate is 13.5M/sec for WLAN and LAN
	Compressed Bit Rate 9: The MPEG compressed bit rate is 14.4M/sec for WLAN and LAN

### TV system



Many TV system parameters are displayed as “[ ]” on the LED.

LED Display	Description
	MTS stereo

These parameters will be chosen by pressing Source to TV, and pushing Enter to TV related parameters than using Up or Down to change it. The parameters are shown via OSD on TV.







Sound system is displayed as follow

OSD	Description
Stereo	MTS stereo

	Channel <b>161</b> : Use 802.11a wireless channel 161 to connect.
	Channel <b>165</b> : Use 802.11a wireless channel 165 to connect.









### MPEG compression rate

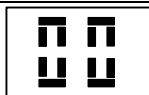



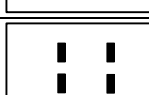

The TA-530wa supports ten types of MPEG-2 compression rates. To change the compression rate, press the Enter button until the LED displays the compression rate and then use the Up or Down button to change the rate. After that, press Enter to save it. When completed, the Receiver will send a request to the Transmitter and the Transmitter will change the compressed bit rate automatically.

LED Display	Description
	Compressed <b>Bit Rate 0</b> : The MPEG compressed bit rate is 5.4M/sec for WLAN or 8M/sec for LAN.
	Compressed <b>Bit Rate 1</b> : The MPEG compressed bit rate is 3M/sec for WLAN or LAN.
	Compressed <b>Bit Rate 2</b> : The MPEG compressed bit rate is 3.6M/sec for WLAN or LAN.
	Compressed <b>Bit Rate 3</b> : The MPEG compressed bit rate is 4.5M/sec for WLAN or LAN.
	Compressed <b>Bit Rate 4</b> : The MPEG compressed bit rate is 5.4M/sec for WLAN or LAN.
	Compressed <b>Bit Rate 5</b> : The MPEG compressed bit rate is 6M/sec for WLAN or LAN.
	Compressed <b>Bit Rate 6</b> : The MPEG compressed bit rate is 6.7M/sec for WLAN and LAN.

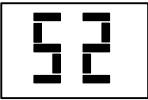
and Receiver will automatically reboot and connect in the new wireless channel.

*Note: Only the last two digits for channel numbers above 100 will be displayed.*

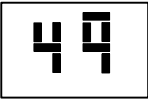
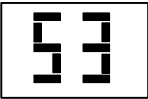
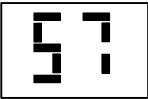
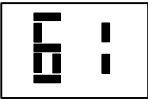







LED Display	Description
	Channel <b>0</b> : Auto search a clean wireless channel. If user sets this parameter, the Transmitter will search a clean channel to wait for the Receiver to connect.
	Channel <b>1</b> : Use 802.11b/g wireless channel 1 to connect.
	Channel <b>4</b> : Use 802.11b/g wireless channel 4 to connect.
	Channel <b>6</b> : Use 802.11b/g wireless channel 6 to connect.
	Channel <b>9</b> : Use 802.11b/g wireless channel 9 to connect.
	Channel <b>11</b> : Use 802.11b/g wireless channel 11 to connect.
	Channel <b>36</b> : Use 802.11a wireless channel 36 to connect.
	Channel <b>40</b> : Use 802.11a wireless channel 40 to connect.
	Channel <b>44</b> : Use 802.11a wireless channel 44 to connect.
	Channel <b>48</b> : Use 802.11a wireless channel 48 to connect.

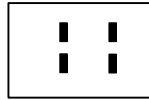
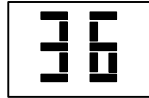
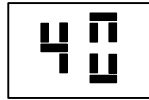
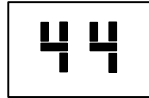
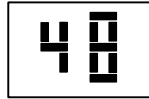

	Channel <b>52</b> : Use 802.11a wireless channel 52 to connect.
	Channel <b>56</b> : Use 802.11a wireless channel 56 to connect.
	Channel <b>60</b> : Use 802.11a wireless channel 60 to connect.
	Channel <b>64</b> : Use 802.11a wireless channel 64 to connect.
	Channel <b>149</b> : Use 802.11a wireless channel 149 to connect.
	Channel <b>153</b> : Use 802.11a wireless channel 153 to connect.
	Channel <b>157</b> : Use 802.11a wireless channel 157 to connect.
	Channel <b>161</b> : Use 802.11a wireless channel 161 to connect.
	Channel <b>165</b> : Use 802.11a wireless channel 165 to connect.

### MPEG Compression Rate

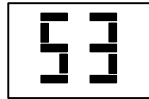
The TA-530wa supports fourteen types of MPEG-2 compression rates. To change the compression rate, press the Enter button until the LED displays the compression rate and then use the Up or Down button to change the rate. After that, press Enter to save it. When completed, the Transmitter will send a request to the Receiver and the Receiver will change the compressed bit rate automatically.

The MPEG compression rates are shown in the figure below.

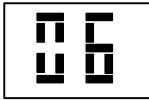
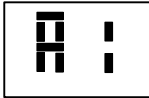



	Channel <b>11</b> : Use 802.11b/g wireless channel 11 to connect.
	Channel <b>36</b> : Use 802.11a wireless channel 36 to connect.
	Channel <b>40</b> : Use 802.11a wireless channel 40 to connect.
	Channel <b>44</b> : Use 802.11a wireless channel 44 to connect.
	Channel <b>48</b> : Use 802.11a wireless channel 48 to connect.
	Channel <b>52</b> : Use 802.11a wireless channel 52 to connect.
	Channel <b>56</b> : Use 802.11a wireless channel 56 to connect.
	Channel <b>60</b> : Use 802.11a wireless channel 60 to connect.
	Channel <b>64</b> : Use 802.11a wireless channel 64 to connect.
	Channel <b>149</b> : Use 802.11a wireless channel 149 to connect.
	Channel <b>153</b> : Use 802.11a wireless channel 153 to connect.
	Channel <b>157</b> : Use 802.11a wireless channel 157 to connect.













	Analog tuner channel
	AV1 input
	AV2 (mini AV) input

### Wireless Channel

The LED will display the WLAN channel when the Enter button is pressed. Use the Up or Down button to change the channels. After changing the LAN or WLAN channel, the Receiver and the Transmitter will automatically reboot and operate in the new wireless channel. If users want to change the connection interface from WLAN to LAN or vice versa, users have to change it from Setup mode.

*Note: Only the last two digits for channel numbers above 100 will be displayed.*

LED Display	Description
	Channel 0: Auto search a clean wireless channel. If user sets this parameter, the Transmitter will scan a clean channel to wait for the Receiver to connect.
	Channel 1: Use 802.11b/g wireless channel 1 to connect.
	Channel 4: Use 802.11b/g wireless channel 4 to connect.
	Channel 6: Use 802.11b/g wireless channel 6 to connect.
	Channel 9: Use 802.11b/g wireless channel 9 to connect.

LED Display	Description
	Compressed Bit Rate 0: The MPEG compressed bit rate is 5.4M/sec for WLAN or 8M/sec for LAN.
	Compressed Bit Rate 1: The MPEG compressed bit rate is 3M/sec for WLAN or LAN.
	Compressed Bit Rate 2: The MPEG compressed bit rate is 3.6M/sec for WLAN or LAN.
	Compressed Bit Rate 3: The MPEG compressed bit rate is 4.5M/sec for WLAN or LAN.
	Compressed Bit Rate 4: The MPEG compressed bit rate is 5.4M/sec for WLAN or LAN.
	Compressed Bit Rate 5: The MPEG compressed bit rate is 6M/sec for WLAN or LAN.
	Compressed Bit Rate 6: The MPEG compressed bit rate is 6.7M/sec for WLAN or LAN.
	Compressed Bit Rate 7: The MPEG compressed bit rate is 7.2M/sec for WLAN or LAN.
	Compressed Bit Rate 8: The MPEG compressed bit rate is 8.0M/sec for WLAN or LAN.
	Compressed Bit Rate 9: The MPEG compressed bit rate is 9M/sec for WLAN or LAN
	Compressed Bit Rate 9: The MPEG compressed bit rate is 10.8M/sec for WLAN and LAN
	Compressed Bit Rate 9: The MPEG compressed bit rate is 12M/sec for WLAN and LAN

	Compressed <b>Bit Rate 9</b> : The MPEG compressed bit rate is 13.5M/sec for WLAN and LAN
	Compressed <b>Bit Rate 9</b> : The MPEG compressed bit rate is 14.4M/sec for WLAN and LAN

### Analog tuner channel

Push the Source button to analog tuner and press Up or Down button to change the analog tuner channel. The analog tuner channel number will be shown on 7-segment 2-digit LED display. When the channel number exceeds 99, the LED will display EA.

LED Display	Description
	Analog Tuner Channel 1
	Analog Tuner Channel 99
	Analog Tuner Channel exceeds 99.

### Input Volume

The Transmitter has input volume control to make sure the audio quality. Some DVD players have volume control function and if users adjust large volume, it will cause the volume blast. To avoid the blast volume, the Transmitter can adjust the input volume.

LED Display	Description
	Input volume is reduced -8db.
	Input volume is reduced -4db.

processing. Otherwise, it will scan all wireless channels to find the Transmitters. If it finds the last connected Transmitter in other WLAN channel, it will automatically connect the Transmitter and start processing. Otherwise, it will show all Transmitters on TV via OSD. Users have to choose the Transmitter by using Up or Down button and press Enter to connect. The Receiver can recognize up to eight Transmitters with but connect only one Transmitter at a time.

The Receiver will use one interface to connect the Transmitter at a time. If users want to change the connection interface from WLAN to LAN or LAN to WLAN, users have to change it in Setup mode.

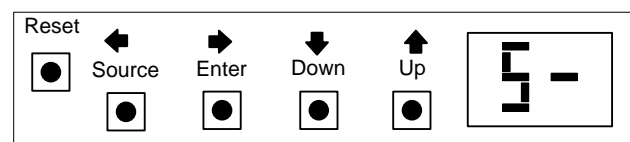

After the connection is established, the TV will display the program sent by the Transmitter and the LED will display the current video source. In this mode, the Source button selects the video source devices connected to the Transmitter and the Up and Down button selects the tuner channel.

Use the Enter button to jump to the parameters that need to be changed. For example, to change the MPEG-2 compression rate, press the Enter button until the LED displays "b0", then use the Up or down button to change the compression rate.

### Video Source

Video source can be selected by using the source button. The analog tuner channel can be selected via the Down and Up buttons.

The descriptions of the LED display are as follow:

LED Display	Description
	S-video input

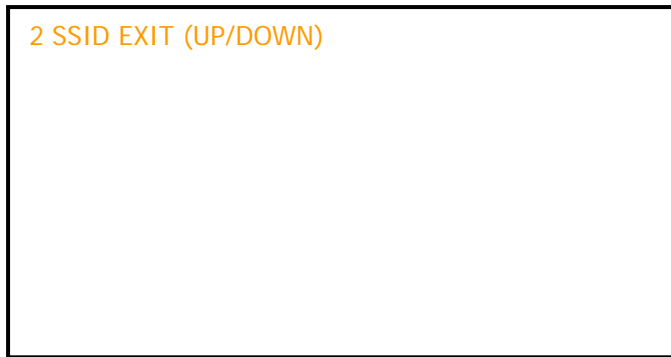

Press UP or down button to see the transmitters. As below figure, one Transmitter WiFi-AV-024A55 (024A55 is the last three digit of WLAN card MAC address) is at WLAN channel 44 (C044). Press Enter (OK on remote controller) to connect.

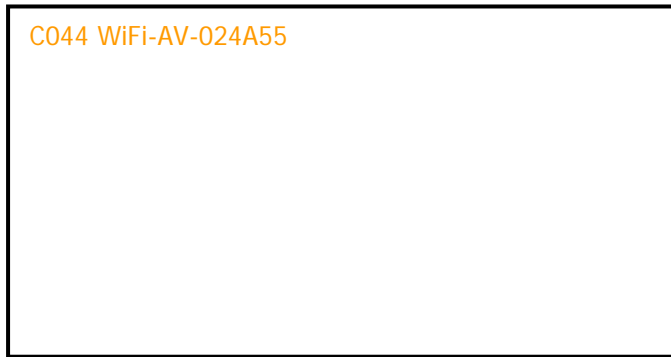

### Factory Reset

Factory reset will load factory default parameters. Using it will lose all configured parameters. It will be done when users want to delete all configurations to reconfigure the receiver. The default transmitter will also be deleted and the receiver will search all transmitters automatically but users have to select one transmitter as default transmitter manually.

### Operation Mode

The Receiver will use the default or last channel which is LAN or WLAN channel to find the last connected Transmitter. If it finds the Transmitter, it will automatically connect the Transmitter and start

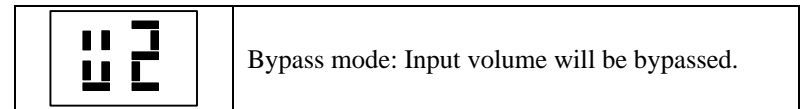

### Scan analog tuner

To perform a TV tuner channel scan, press the Source button until the TV input source and press the Enter button until the LED displays "SC" and then press the Up or Down button to begin the scan. After that the transmitter will jump to channel 1.

LED Display	Description
	Analog Tuner SCan

### The Receiver

The main function of the receiver is receiving the MPEG-2 Transport Stream from the LAN or WLAN and decoding it into audio and video data and sending them to the TV.



Receiver also has two network interfaces, LAN and WLAN. The default IP address is 192.168.1.22 for both. The Receiver can recognize up to 8 Transmitters, but only one can be connected at a time.

### Configuring the Receiver

Like the Transmitter, the Receiver has Download mode, Setup mode and Operation mode. The Receiver displays the setup parameters on the TV using OSD. To see the setup parameters, turn on the TV and change the input source to the method the Receiver is connected to the TV. i.e., if the Receiver and the TV are connected via an S-Video cable, change the input source to S-Video.

### Download Mode

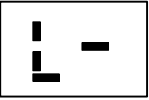
In this mode, the receiver is initializing the system. When powered on, the LED will display "L-" (download firmware). "SE" indicates it is setup mode.

LED Display	Description
	Download Mode
	Setup Mode
	S-Video input.

After initialization, the TA-530wa will enter into the Operation mode. Use the following figure for the button definitions. To change the network parameters, hold the Enter button down until the TV displays the network parameters.

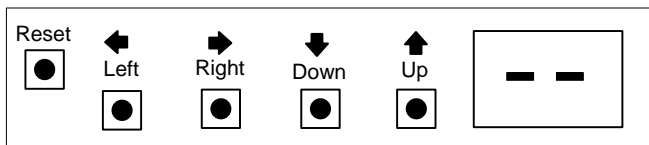

### Setup Mode

The network parameters can be configured by using Left, Right, Down and Up buttons. Press the Down button to jump to the next item and Up to the previous item. Left and Right button is used for changing the parameters. The flashing item will be changed by using Up and Down buttons. When completed, jump to EXIT and press Left or Right button. The password is to get the video contents from the Transmitter and so users have to setup the same password as the Transmitter.

The Transmitters have password protection to get audio and video data from it. The receiver has to be configured the Transmitter password at A/V TRANSMITTER PASSWORD field. Otherwise, the Transmitter will not deliver audio and video data to the Receiver.

The television will show the following:

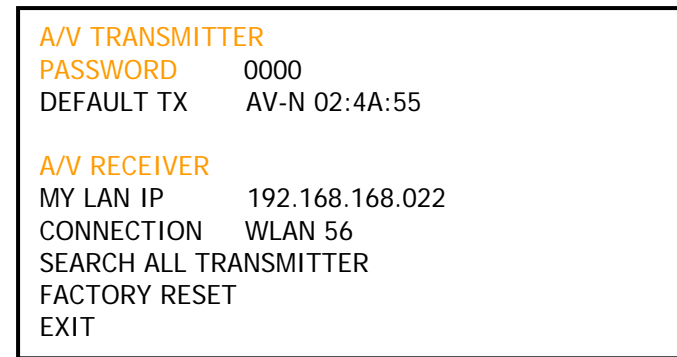

### Search all transmitter

The receiver can recognize up to eight transmitters but connect one at a time. If the receiver was connected to one transmitter, the transmitter will be shown on DEFAULT TX (Default transmitter) and the receiver will search to connect it at any time power on. If users want to search all transmitters (two or more transmitters are available in your network), jump to the SEARCH ALL TRANSMITTER and press Enter (OK on remote controller). TV displays transmitter searching screen.

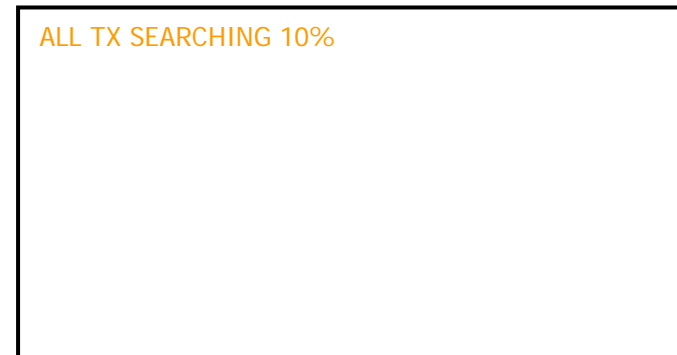

For instance, there are two transmitters and TV will display as figure.